

Motor Cycle Lift

XTL-MJ500F

ORIGINAL OPERATION MANUAL



The specifications stated on this brochure are not binding. We reserve the right to change the specification without notice

FOLLOW THE INSTRUCTIONS CAREFULLY TO GRANT THE MACHINE A CORRECT FUNCTION AND LONG SERVICE LIFE.

CONSERVING THE MANUAL





The manual is an integral part of the lift, which it should always accompany even if the unit is sold .The manual, must be kept in the vicinity of the lift in an easily accessible place so that the operator and maintenance staff must be able to locate and consult the manual quickly at any time.



ATTENTIVE AND REPEATED READING OF SAFETY INSTRUCTION, WHICH CONTAINS IMPORTANT INFORMATION AND SAFETY WARNINGS, IS PARTICULARLY RECOMMENDED.

PRINTING CHARACTERS AND SYMBOLS

Throughout this manual, the following symbols and printing characters are used to facilitate reading:

	Indicates the operations which need proper care
	Indicates prohibition
	Indicates a possibility of danger for the operators
	Indicates the direction of access for motor vehicles to the lift
BOLD TYPE	Important information

WARNING:
before operating the lift and carrying out any adjustment, read carefully chapter 7
“installation” where all proper operations for a better functioning of the lift are shown.

CONTENTS

CHAPTER 1 – GENERAL INFORMATION	4
1.1 MANUAL KEEPING	4
1.2 OBLIGATION IN CASE OF MALFUNCTION	4
1.3 CAUTIONS FOR THE SAFETY OF THE OPERATOR	4
1.4 WARNINGS	5
CHAPTER 2 – PRODUCT IDENTIFICATION	6
2.1 WARRANTY CERTIFICATE	6
2.2 TECHNICAL SERVICING	6
CHAPTER 3 - PACKING, TRANSPORT AND STORAGE	7
3.1 PACKING	7
3.2 LIFTING AND HANDLING	7
3.3 STORAGE AND STACKING OF PACKAGES	7
3.4 DELIVERY AND CHECK OF PACKAGES	8
CHAPTER 4 - PRODUCT DESCRIPTION	9
4.1 LIFT (ref. figure 2)	9
4.2 OPERATION	10
CHAPTER 5 - TECHNICAL SPECIFICATION	11
5.1 SIZE AND MAIN FEATURES (Ref. Figure 3)	11
5.2 PUMP	11
CHAPTER 6 - SAFETY	12
6.1 GENERAL WARNINGS	14
6.2 RISKS DURING VEHICLE LIFTING	15
6.3 RISKS FOR PEOPLE	15
6.4 PERSONNEL CRUSHING RISKS	15
6.5 BUMPING RISK	15
6.6 RISK OF THE VEHICLE FALLING FROM THE LIFT	15
6.7 SLIPPING RISKS	1
6.8 ELECTROCUTION RISKS	16
6.9 RISKS RESULTING FROM IMPROPER LIGHTING	16
6.10 RISKS OF BREAKING COMPONENT DURING OPERATION	16
6.11 RISKS FOR UNAUTHORIZED USES	16
CHAPTER 7 - INSTALLATION	17
7.1 CHECKING FOR ROOM SUITABILITY	17
7.2 LIGHTING	17
7.3 INSTALLATION SURFACE	17
7.4 RUNWAY ASSEMBLY AND CONTROL DESK POSITIONING	18
7.5 HYDRAULIC SYSTEM CONNECTION (Rif. Fig. 16)	18
7.6 PNEUMATIC SUPPLY CONNECTION	19
7.7 STARTING	19
7.7.1 MECHANICAL CHECKS	错误！未定义书签。
7.7.2 HYDRAULIC SYSTEM CHECK	错误！未定义书签。
7.8 SET UP AND ADJUSTMENTS	19
7.8.1 LOAD LESS CHECK	19
7.8.2 CHECK WITH LOAD	20
7.8.3 BOLTS AND NUTS CHECK	20
7.8.4 MOVABLE PLATFORM ROTATION	20
CHAPTER 8 - OPERATION AND USE	21
8.1 CONTROLS	21
8.2 MOTORCYCLE POSITIONING	22
8.3 LIFTING	22
8.4 STANDING	23
8.5 LOWERING	23
CHAPTER 9 Hydraulic drawing	24
CHAPTER 10 - MAINTENANCE	24
10.1 ORDINARY MAINTENANCE	24
10.2 PERIODIC MAINTENANCE	25
CHAPTER 11 - TROUBLESHOOTING	25

CHAPTER 1 –GENERAL INFORMATION

This chapter contains warning instructions to operate the lift properly and prevent injury to operators or objects.

This manual has been written to be used by shop technicians in charge of the lift (operator) and routine maintenance technician (maintenance operator).

The operating instructions are considered to be an integral part of the machine and must remain with it for its whole useful life.

Read every section of this manual carefully before operating the lift and unpacking it since it gives helpful information about:

- SAFETY OF PEOPLE
- SAFETY OF THE LIFT
- SAFETY OF LIFTED VEHICLES

The company is not liable for possible problems, damage, accidents, etc. resulting from failure to follow the instructions contained in this manual.

Only skilled technicians of AUTHORISED DEALERS or SERVICE CENTRES AUTHORISED by the manufacturer shall be allowed to carry out lifting, transport, assembling, installation, adjustment, calibration, settings, extraordinary maintenance, repairs, overhauling and dismantling of the lift.

THE MANUFACTURER IS NOT RESPONSIBLE FOR POSSIBLE DAMAGE TO PEOPLE, VEHICLES OR OBJECTS IF SAID OPERATIONS ARE CARRIED OUT BY UNAUTHORIZED PERSONNEL OR THE LIFT IS IMPROPERLY USED.

Any use of the machine made by operators who are not familiar with the instructions and procedures contained herein shall be forbidden.

1.1 MANUAL KEEPING

For a proper use of this manual, the following is recommended:

- keep the manual near the lift, in an easily accessible place
- keep the manual in an area protected from the damp
- use this manual properly without damaging it.
- Any use of the machine made by operators who are not familiar with the instructions and procedures contained herein shall be forbidden.

This manual is an integral part of the lift: it shall be given to the new owner if and when the lift is resold

1.2 OBLIGATION IN CASE OF MALFUNCTION



In case of machine malfunction, follow the instructions contained in the following chapters.

1.3 CAUTIONS FOR THE SAFETY OF THE OPERATOR

Operators must not be under the influence of sedatives, drugs or alcohol when operating the machine.



Before operating the lift, operators must be familiar with the position and function of all controls, as well as with the machine features shown in the chapter “Operation and use”

1.4 WARNINGS



Unauthorized changes and/or modifications to the machine relieve the manufacturer of any liability for possible damages to objects or people. Do not remove or make inoperative the safety devices, this would cause a violation of safety at work laws and regulations.



Any other use which differs from that provided for by the manufacturer of the machine is strictly forbidden.



The use of non genuine parts may cause damage to people or objects

DECLARATION OF WARRANTY AND LIMITATION OF LIABILITY

The manufacturer has paid proper attention to the preparation of this manual. However, nothing contained herein modifies or alters, in any way, the terms and conditions of manufacturer agreement by which this lift was acquired, nor increase, in any way, manufacturer’s liability to the customer.

TO THE READER

Every effort has been made to ensure that the information contained in this manual is correct, complete and up-to date. The manufacturer is not liable for any mistakes made when drawing up this manual and reserves the right to make any changes due the development of the product, at any time.

CHAPTER 2 – PRODUCT IDENTIFICATION

The identification data of the machine are shown in the label placed on the frame and indicated in the declaration of conformity.

MOTOR CYCLE LIFT		CE
● Model: XTL-MJ500F	● Manu. Date: _____	
● Rated load: 500Kg	● Serial No.: _____	
● Lifting height: 800mm	● Net Weight: 350kg	
● Pneumatic Press.: 90~100 PSI	● Machine size: 2650×610×800 (mm)	

	Use the above data both to order spare parts and when getting in touch with the manufacturer (inquiry). The removal of this label is strictly forbidden.
---	---

Machines may be updated or slightly modified from an aesthetic point of view and, as a consequence, they may present different features from these shown, this without prejudicing what has been described herein.

2.1 WARRANTY CERTIFICATE

The warranty is valid for a period of 12 months starting from the date of the purchase invoice. The warranty will come immediately to an end when unauthorized modifications to the machine or parts of it are carried out. The presence of defects in workmanship must be verified by the Manufacturer's personnel in charge.

2.2 TECHNICAL SERVICING

For all servicing and maintenance operations not specified or shown in these instructions, contact your Dealer where the machine has been bought or the Manufacturer's Commercial Department.

CHAPTER 3 - PACKING, TRANSPORT AND STORAGE

Only skilled personnel who are familiar with the lift and this manual shall be allowed to carry out packing, lifting, handling, transport and unpacking operations.

3.1 PACKING

The lift is delivered in many components that appears sub-assembled.
The lay-out is referred to the model.

In ground model

- No. 1 base units with a platform and hydraulic cylinders
- No. 1 pneumatic pedal pump

If requested, optional accessories are available to satisfy each customer's requirements (Ref. accessories manual and price lists)

The lift is packed in a single box on a wooden bed, wrapped up in non-scratch waterproof material and sealed with 2 straps.

The average weight of the package is 200 kg

3.2 LIFTING AND HANDLING

When loading/unloading or transporting the equipment to the site, be sure to use suitable loading (e.g. cranes, trucks) and hoisting means. Be sure also to hoist and transport the components securely so that they cannot drop, taking into consideration the package's size, weight and centre of gravity and it's fragile parts.

Figure 1 – PACKAGE AND HANDLING

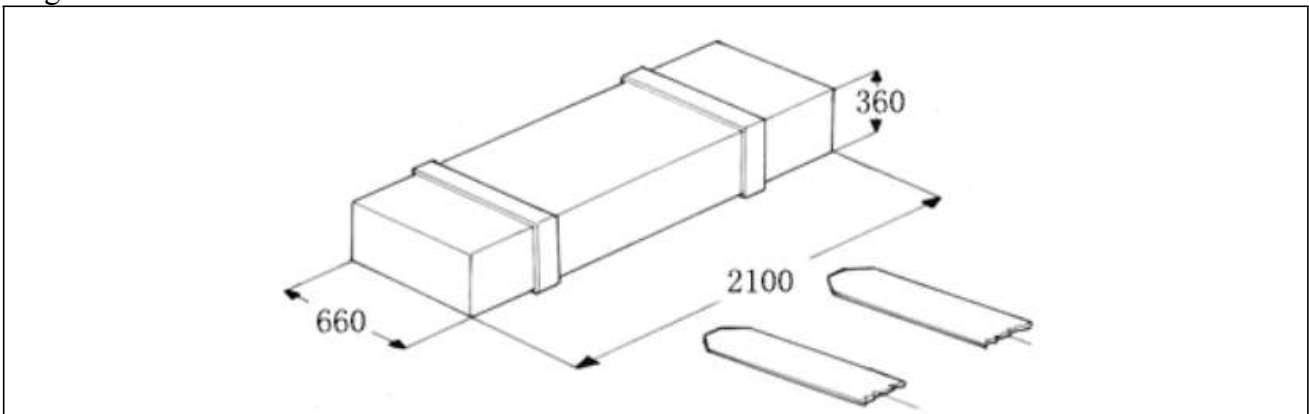

Hoist and handle only one package at a time

3.3 STORAGE AND STACKING OF PACKAGES

Packages must be stored in a covered place, out of direct sunlight and in low humidity, at a temperature between -10°C and +40°C.

Stacking is not recommended: the package's narrow base, as well as its considerable weight and size make it difficult and hazardous.

3.4 DELIVERY AND CHECK OF PACKAGES

When the lift is delivered, check for possible damages due to transport and storage; verify that what is specified in the manufacturer's confirmation of order is included. In case of damage in transit, the customer must immediately inform the carrier of the problem.

Packages must be opened paying attention not to cause damage to people (keep a safe distance when opening straps) and parts of the lift (be careful the objects do not drop from the package when opening).

CHAPTER 4 - PRODUCT DESCRIPTION

4.1 LIFT (ref. figure 2)

The lift has been designed to lift motorcycles and make them stand at any level between the minimum and maximum height.

The maximum lifting weight, including any additional load on the vehicle, is as specified on the serial plate.

All mechanical frames, such as platforms, extensions, base frames and arms have been built in steel plate to make the frame stiff and strong while keeping a low weight.

The operation is described in detail in chapter 8.

This chapter describes the lift showing the principal elements so as to allow the user to be familiar with the machine.

As shown in Figure2, the lift is composed of one platform (1) connected to the base frame (2) and anchored to the ground by means of a set of bolts

The platform is linked to the base frame by means of a pair of arms (5)

The platform is equipped with a ramp (3) which can pull out for access of a motorcycle and be folded under the working table when the lift is completely lifted.

The lifting system is composed of two arms (4) and one cylinder (5).

Lift lowering and lifting are carried out by means of an air-hydraulic pedal pump

The mechanical safety (6) operating by a slider (7) is installed at the base of the inside arm

The motorcycle anchorage to the lift platform is carried out by means of side bands (8), supplied with the lift.

Figure 2 - *LIFT*

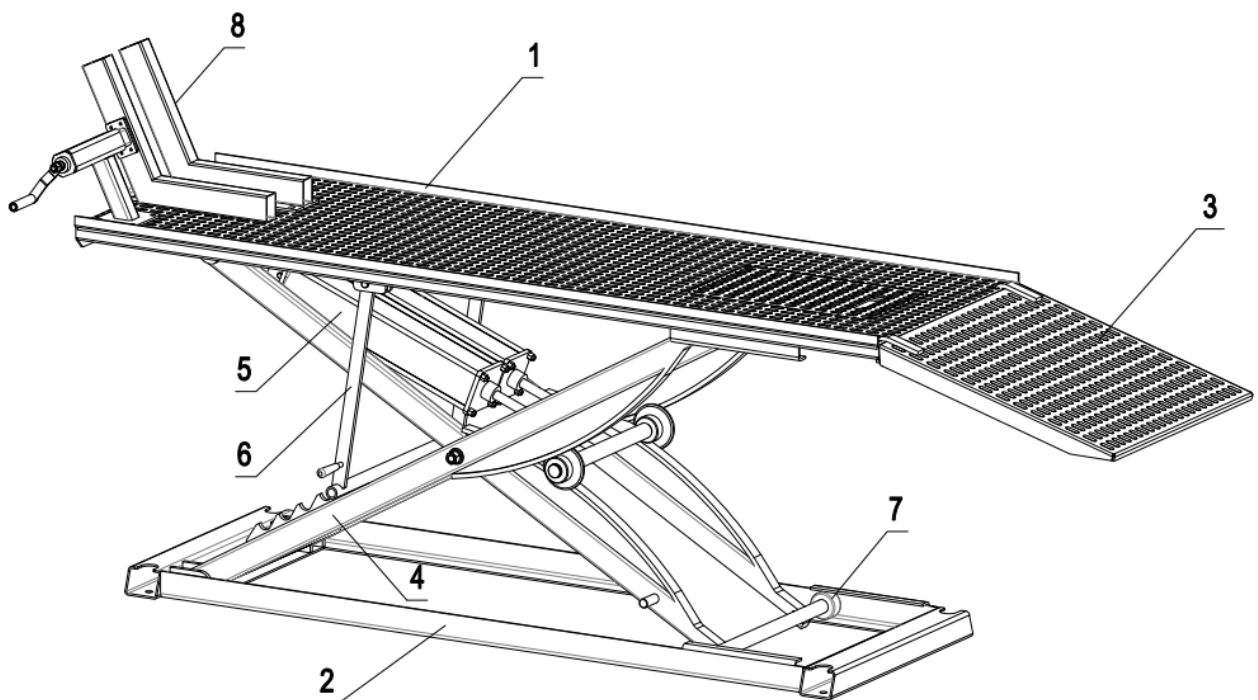

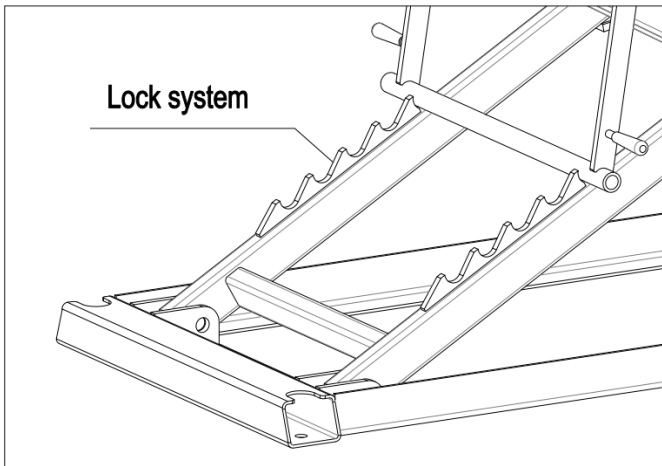

4.2 OPERATION

	<p>Before carrying out any operation, secure the motorcycle to the platform by means of the specially provided clamping straps</p> <p>The motorcycle lifting with the straps not properly secured or without straps at all is strictly forbidden</p>
--	--

Platform lifting is carried out by the air-hydraulic pump which acts upon the cylinder.

The hydraulic system is protected by a maximum pressure control valve in the air-hydraulic pump preventing the pressure from exceeding the maximum fixed safety limit

Lifting/lowering motion of the lift is controlled by the panel placed on the air-hydraulic pump.

The mechanical safety prevents the runway from accidental or uncontrolled lowering in case of hydraulic system malfunction or leakage in the hydraulic circuit hose.

Lowering is carried out by the weight of both the platform and the load lifted.

CHAPTER 5 - TECHNICAL SPECIFICATION

5.1 SIZE AND MAIN FEATURES (Ref. Figure 3)

	TD-MJ500A
Capacity	500 kg
Maximum lifting height	830 mm
Minimum height of lift	200 mm
Length of the lift	2800 mm
Width of the lift	610 mm
Width of platforms	1290 mm
Lifting time	30 s
Working temperature	-10 °C ~ 40 °C
Average weight of the package	350kg

5.2 PUMP

Type	Air-hydraulic
Compressed air pressure	3 bar – 10 bar
Max. working hydraulic pressure	700 bar (10000 psi)
Volume of oil reservoir	750cc

Figure 3-LAYOUT

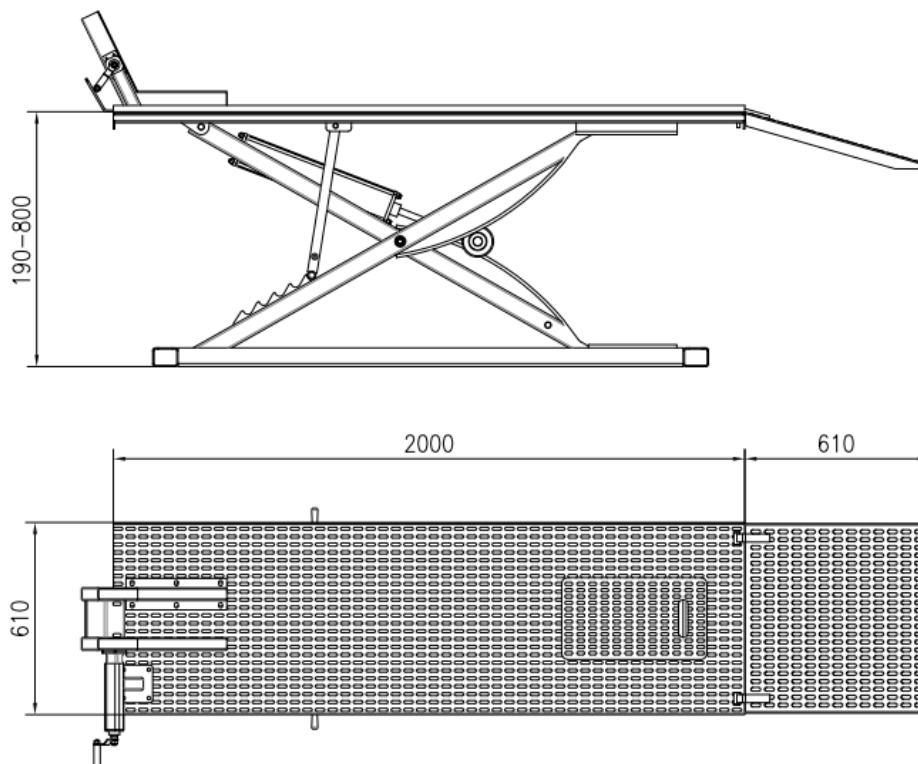
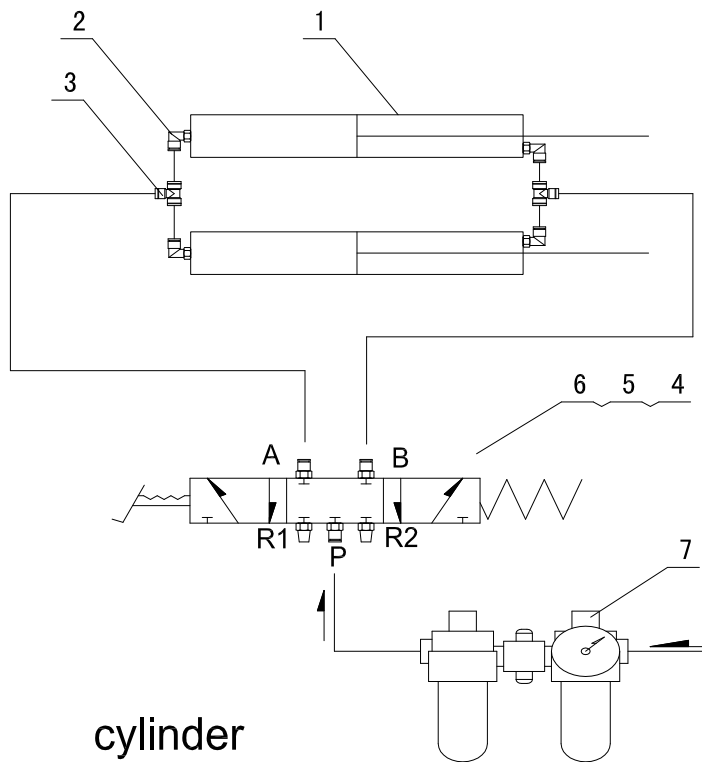

Figure 4 - HYDRAULIC PLAN



- 1 cylinder
- 2 L type threaded two way pipe
- 3 T type three way pipe
- 4 silencer
- 5 threaded direct way pipe
- 6 Foot Valve
- 7 F.R.L Combination

CHAPTER 6 - SAFETY

Safety instructions

Safety Instructions for Commissioning

The lift may be installed and commissioned by authorized service personnel only.
 The standard lift version may not be installed and commissioned in the vicinity of explosives or flammable liquids, outdoors or in moist rooms (e.g. car wash).

Safety Instructions for Operation

Read the operating manual.

Lift operation by authorized personnel over 18 years only.

Always keep the lift and lift area clean and free of tools, parts, debris etc.

Once the pad adapters contact the lift points, check restraints for engagement.

After raising the vehicle briefly, stop and check the disk adapters for secure contact.

Always lift the vehicle using all pad adapters.

Make sure the vehicle doors are closed during raising and lowering cycles.

Closely watch the vehicle and the lift during raising and lowering cycles.

Do not allow anyone to stay in lift area during raising and lowering cycles.

Do not allow anyone on lift or inside raised vehicle.

Only use the lift for its intended purpose.

Comply with the applicable accident prevention regulations.

Do not overload the lift. The rated load capacity is indicated on the lift nameplate.

Only use the vehicle manufacturer's recommended lift points.

After positioning the vehicle apply the parking brake.

Use caution when removing or installing heavy components (center-of-gravity displacement).

The main switch serves as emergency switch and in case of emergency turn to position 0.

Protect all parts of the electrical equipment from humidity and moisture.

Protect the lift against unauthorized usage by padlocking the main switch.

Safety Instructions for Servicing

Maintenance or repair work by authorized service personnel only.

Turn off and padlock the main switch before doing any maintenance, or repair work.

Work on pulse generators or proximity switches by authorized service personnel only.

Work on the electrical equipment by certified electricians only.

Ensure that ecologically harmful substances are disposed of only in accordance with the appropriate regulations.

Do not use high pressure / steam jet cleaners or caustic cleaning agents. Risk of damage!

Do not replace or override the safety devices.

Operating digest

1. The operation of the lift is permitted by authorized persons only.
2. It is necessary to refer to the complete operation instruction, especially for trouble shooting.
3. The field of motion of the load and of the load carrying devices shall be free of obstructions.
4. It shall draw attention to the safe method of carrying the load and to the rule that, after raising a short distance, the vehicle shall be checked to ensure that it correctly and safely positioned.

5. It shall draw attention to the rule that the carrying device shall be observed by the operator throughout the motion of the lift.
6. It is forbidden for people to stand in the field of the motion of the load and the load carrying device during the movement.
7. It is forbidden to climb onto the load or load carrying device when they are raised unless via a specially designed access.

Read this chapter carefully and completely because it contains important information for the safety of the operator and the person in charge of maintenance

	<p>The lift has been designed and built for lifting vehicles and making them stand above level in a closed area. any other use is forbidden.</p> <p>the manufacturer is not liable for possible damages to people, vehicles or objects resulting from an improper or unauthorized use of the lift.</p>
---	--

For operator and people safety, the safety area shown in Figure 5 must be vacated during lifting and lowering. The lift must be operated only from the operator's control site, as shown. Operator's presence under the vehicle, during working, is only admitted when the vehicle is lifted and platforms are not running

	<p>Ever use the lift when safety devices are off-line. People, the lift and the vehicles lifted can be seriously damaged if these instructions are not followed.</p>
--	---

Figure 5 - SAFETY AREA



SAFETY AREA (min. 1 meter)

6.1 GENERAL WARNINGS

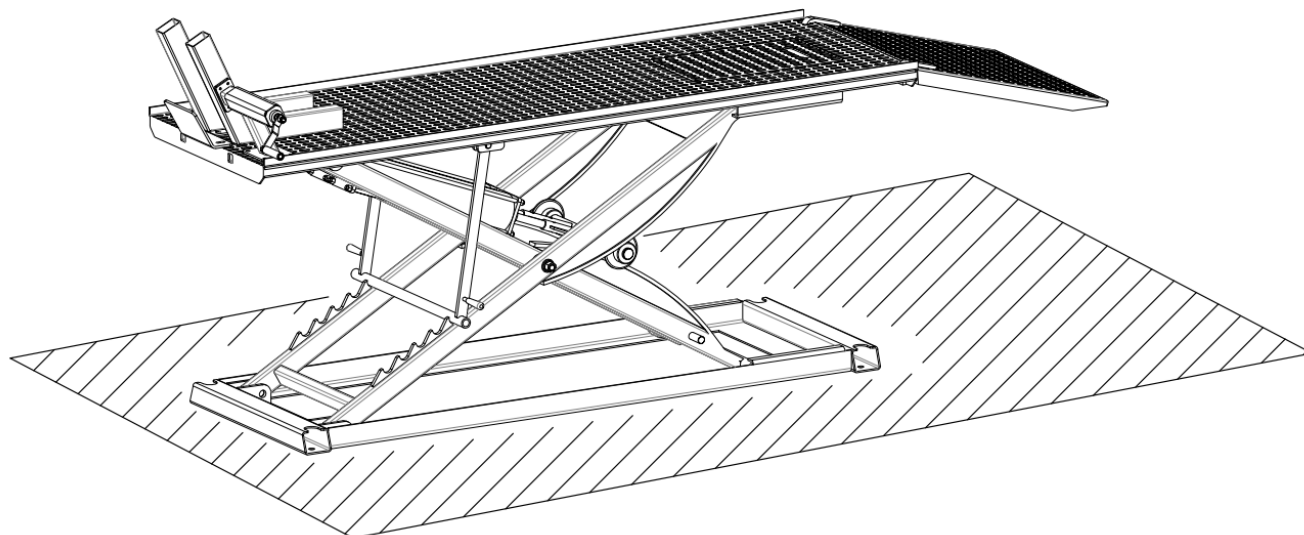
The operator and the person in charge of maintenance must follow accident-prevention laws and rules in force in the country where the lift is installed

They also must carry out the following:

- Neither removes nor disconnects hydraulic, or other safety devices;

- Carefully follow the safety indications applied on the machine and included in the manual;
- observe the safety area during lifting;
- be sure the motor of the vehicle is off, the gear engaged and the parking brake put on;
- be sure only authorized vehicles are lifted without exceeding the maximum lifting capacity;
- verify that no one is on the platforms during lifting or standing.

6.2 RISKS DURING VEHICLE LIFTING

To avoid overloading and possible breaking, the following safety devices have been used:

- a maximum pressure valve placed inside the hydraulic unit to prevent excessive weight.
- a special design of the hydraulic system, in case of pipeline failure, to prevent sudden lift lowering.

6.3 RISKS FOR PEOPLE

All risks the personnel could run, due to an improper use of the lift, are described in this section.

6.4 PERSONNEL CRUSHING RISKS

During lowering of runways and vehicles, personnel must not be within the area covered by the lowering trajectory. The operator must be sure no one is in danger before operating the lift.



Fig. 6a



Fig. 6b



Fig. 6c

6.5 BUMPING RISK

When the lift is stopped at relatively low height for working, the risk of bumping against projecting parts occurs.



Fig. 7

6.6 RISK OF THE VEHICLE FALLING FROM THE LIFT

Vehicle falling from the lift can be caused when the vehicle is improperly placed on platforms, and when its dimensions are incompatible with the lift or by excessive movement of the vehicle. In this case, keep immediately away from the working area.



Fig. 8a



Fig. 8b

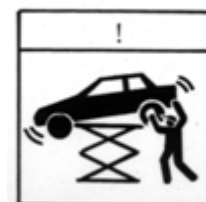

Fig. 8c

6.7 SLIPPING RISKS

The risk of slipping can be caused by oil or dirt on the floor near the lift.



Fig. 9



Keep the area under and around the lift clean. Remove all oil spills

6.8 ELECTROCUTION RISKS

Avoid use of water, steam, solvent, varnish jets in the lift area where electric cables are placed and, in particular, next to the electric panel.

6.9 RISKS RESULTING FROM IMPROPER LIGHTING

Make sure all areas next to the lift are well and uniformly lit, according to local regulations.

6.10 RISKS OF BREAKING COMPONENT DURING OPERATION

Materials and procedures, suitable for the designed parameters of the lift, have been used by the manufacturer to build a safe and reliable product. Operate the lift only for the use it has been designed for and follow the maintenance schedule shown in the chapter “Maintenance”.



Fig. 10

6.11 RISKS FOR UNAUTHORIZED USES

The presence of unauthorized persons next to the lift and on the platforms is strictly forbidden during lifting as well as when the vehicle has been already lifted



Fig. 11



Any use of the lift other than that herein specified can cause serious accidents to people in close proximity of the machine.

CHAPTER 7 - INSTALLATION



Only skilled technicians, appointed by the manufacturer, or by authorized dealers, must be allowed to carry out installation. serious damage to people and to the lift can be caused if installations are made by unskilled personnel.



Before carrying out any operations, remember to insert the safety piece of wood (1) between the lower booms and the base frame.

Figure 12 - SAFETY BLOCK

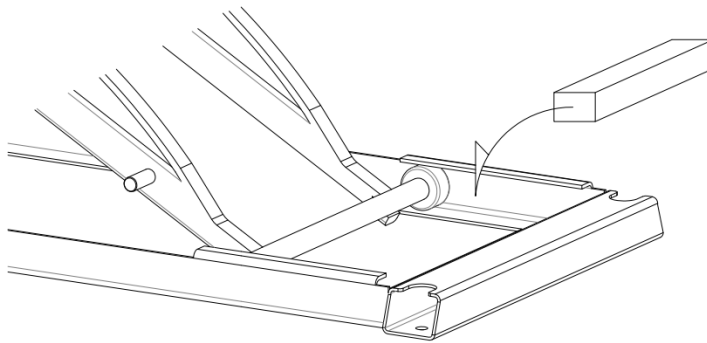

PRELIMINARY OPERATIONS

7.1 CHECKING FOR ROOM SUITABILITY

The lift has been designed to be used in covered and sheltered places.

The place of installation must not be next to washing areas, painting workbenches, solvent or varnish deposits. The installation near to rooms, where a dangerous situation of explosion can occur, is strictly forbidden. The relevant standards of the local Health and Safety at Work regulations, for instance, with respect to minimum distance to wall or other equipment, escapes and the like, must be observed.

7.2 LIGHTING

Lighting must be carried out according to the effective regulations of the place of installation. All areas next to the lift must be well and uniformly lit.

7.3 INSTALLATION SURFACE

The lift must be placed on level floor and sufficiently resistant. The surface and foundation must be suitable for bearing maximum stress values, also in unfavorable working conditions.

7.4 RUNWAY ASSEMBLY AND CONTROL DESK POSITIONING



Unauthorized persons are not allowed to enter the installation area during assembly.

- Transport platforms to the installation site by using hoisting means with load capacity of *500 kg* at least
- To prevent the platform from dropping during transport, it should be lifted according to its centre of gravity.
- Always raise platforms by holding them on the underside of the base frames
- Position the base frames on the foundation according to the drive-on direction of the lift
- Lift platforms with auxiliary equipment by using strong ropes, bands and chains and insert the safety blocks supplied with the lift.

7.5 HYDRAULIC SYSTEM CONNECTION (Rif. Fig. 16)

- connect hydraulic hose to the cylinder
- tighten thoroughly
- connect hydraulic pipe to the fittings placed on the air-hydraulic pump
- tighten thoroughly.

Figure 13 - HYDRAULIC PIPES CONNECTION

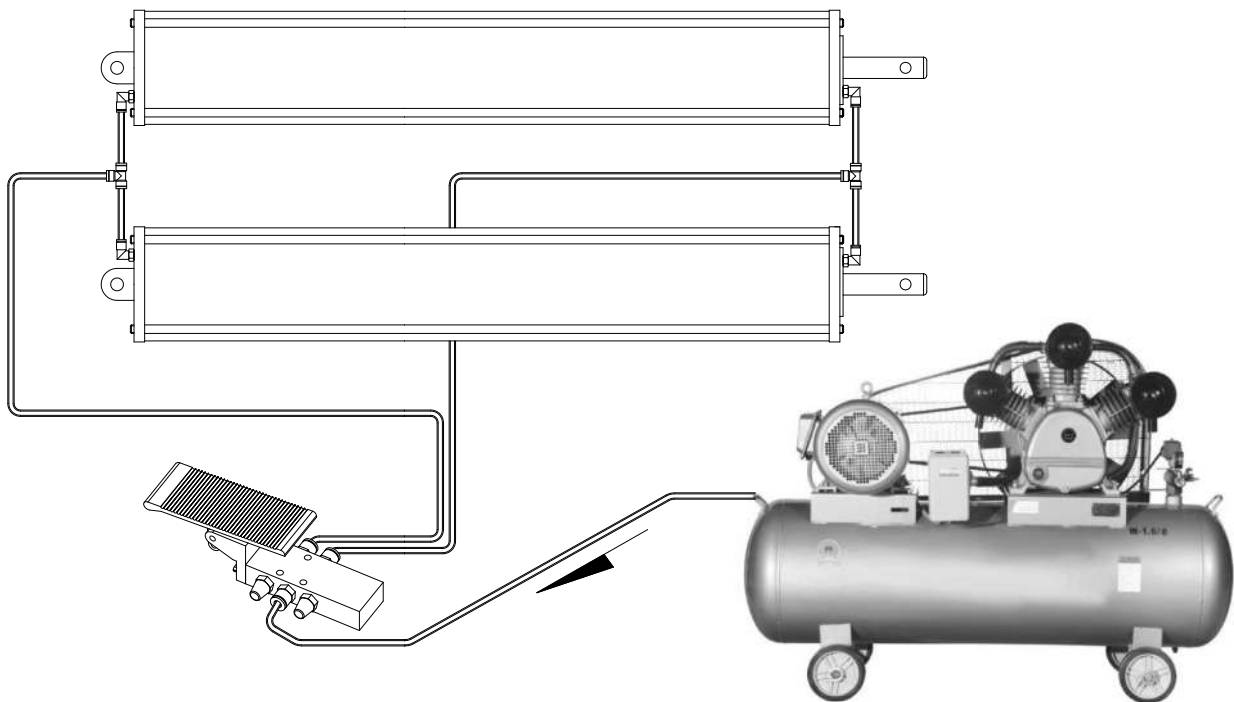

7.6 PNEUMATIC SUPPLY CONNECTION

The pneumatic supply at site (to which the air-hydraulic pump is connected) must be equipped with a servicing unit composed of water separator, lubricator and pressure reducer. These devices can be supplied by the manufacturer on request.

- Connect the air-hydraulic pump to the pneumatic supply at site;
- Check the pneumatic control operations for proper performance.

7.7 STARTING

- Be sure the working area is free from people and objects;
- supply the air power to the air-hydraulic pump;
- Operate the pump until the lift reaches the maximum height;
- Operate the pump to lower the lift to the ground

7.8 SET UP AND ADJUSTMENTS

7.8.1 LOAD LESS CHECK

Carry out two or three complete cycles of lowering and lifting and check:

- the lift for reaching its maximum height



WARNING: please follow carefully the instructions in the coming paragraph for avoiding damages on the lift.

7.8.2 CHECK WITH LOAD

Carry out two or three complete cycles of lowering and lifting and check:

- The lift for reaching its maximum height
- No leakage and blow-by
- Cylinder operation

7.8.3 BOLTS AND NUTS CHECK

After carrying out the checks with load, make a visual inspection of the machine and check bolts and nuts for proper tightening.

7.8.4 MOVABLE PLATFORM ROTATION

In order to operate on the motorcycle rear wheel, the drive-on ramp (1) must be inserted into the movable platform (2)



Be sure the ramp folds perfectly into its seat in a way to prevent it from falling.

Without removing the ramp (1), take out the movable platform (2) until it can rotate downwards and be perpendicular to the lift platform, and then push it forward

Figure 14 - MOVABLE PLATFORM ROTATION

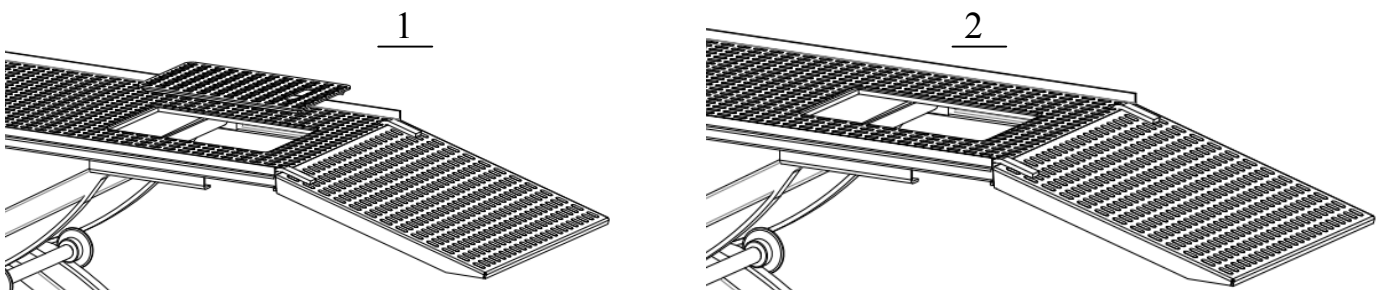

CHAPTER 8 - OPERATION AND USE

NOTE: below description is about pneumatic hydraulic system. If the lift is equipped with electrical hydraulic system, please find relative information in this chapter.

Never operate the lift with any person or equipment below.

	<p>Never exceed the rate lifting capacity.</p> <p>Always ensure that the safeties are engaged before any attempt is made to work on or near the vehicle.</p> <p>Never leave the lift in an elevated position unless the safeties are engaged.</p> <p>If an anchor bolt becomes loose or any component of the lift is found to be defective, DO NOT USE THE LIFT until repairs are made.</p>
---	---

8.1 CONTROLS

Controls for operating the lift are:

LIFTING PEDAL (1)

When pressed, the air fluid is started to be delivered from the Cylinder of the pump into the lift cylinder: the lift begins to rise.

LOWERING PEDAL (2)

When pressed, the air is started to be released: the lift begins to lower.
The lowering speed can be controlled by change of the foot pressing force on the pedal.

SAFETY SLIDER (3)

When moved backward, the mechanical safeties can be released.
When moved forward. The mechanical safeties can be locked.

Figure 15 - CONTROLS

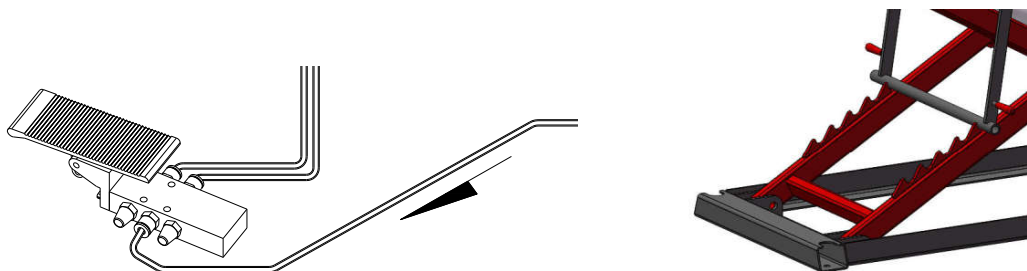

	<p>Be sure the safety area is free from people and objects during the final travel</p>
---	---

Lift operation can be summarized into four steps:

8.2 MOTORCYCLE POSITIONING

Place the motorcycle as follows

- Place the motorcycle on the lift and lean it on the stand;
- place the wheel clamp along the platform slot holes and move it as much as possible near the front wheel; pull or reposition the motorcycle if necessary;
- fix the front wheel properly by means of the wheel clamp;
- hook the clamping straps to the handlebar and tighten

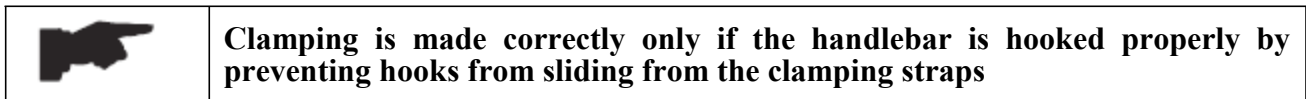
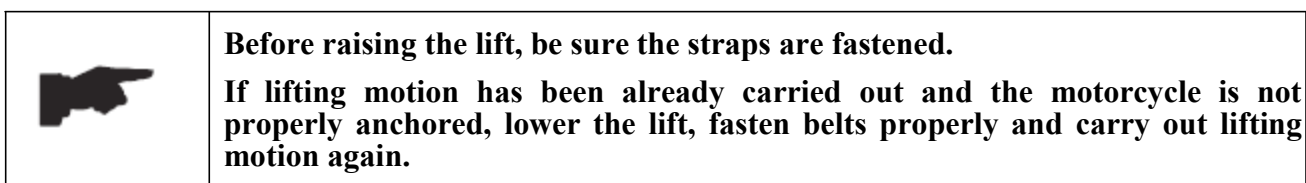
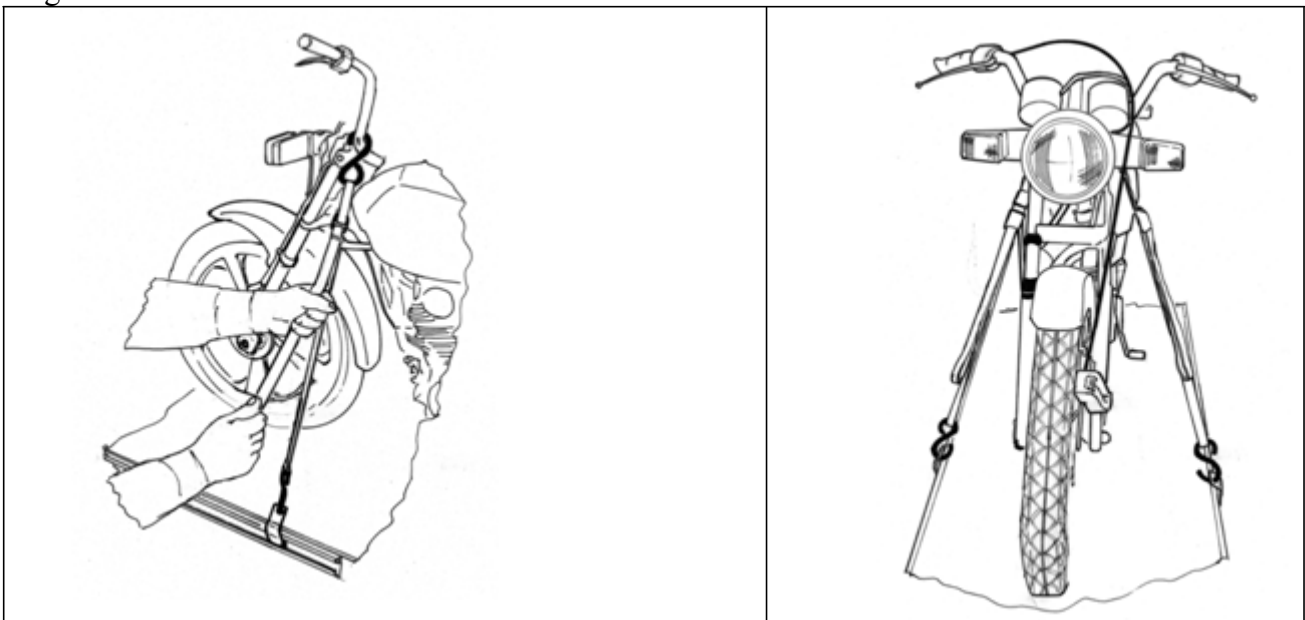
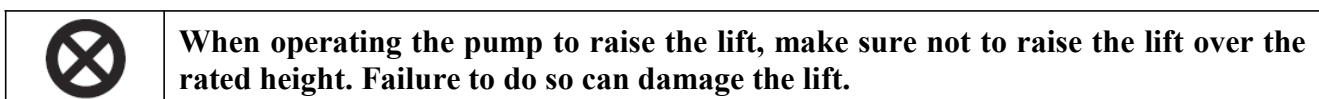

Figure 17 - MOTORCYCLE POSITIONING



8.3 LIFTING

- Keep pressing the lifting pedal until the lift reaches the required level.



8.4 STANDING

- When the required position is reached, lower the lift to engage the mechanical safety and let the lift stand.

8.5 LOWERING

- Be sure the safety area is free of people and objects;
- Press the lifting pump to raise the lift a little bit to clear off the safety;
- Turn the safety handle clockwise to release the mechanical safety
- Keep pressing the lowering pedal, the lift will descend under the motorcycle's and its own weight. The lowering speed can be controlled by change of the pressing force on the pedal;
- Lower the lift completely.

CHAPTER 9

PNEUMATIC DRAWING

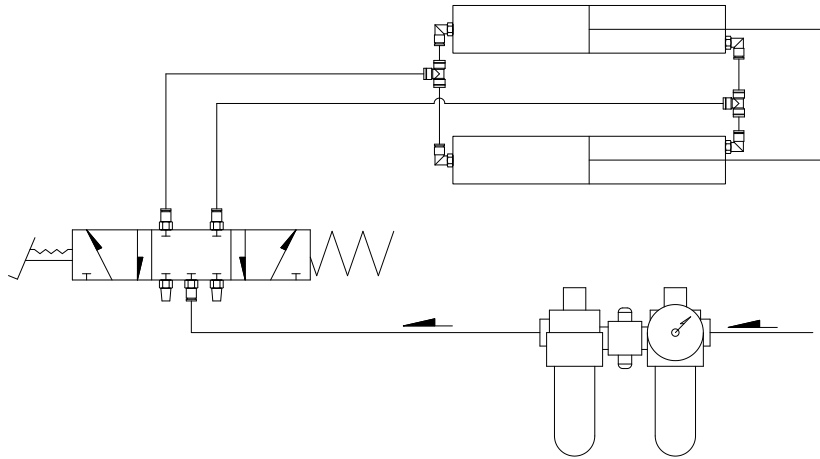

CHAPTER 10 - MAINTENANCE



Only trained personnel who knows how the lift works, must be allowed to service the lift.

To service properly the lift, the following has to be carried out:

- use only genuine spare parts as well as equipment suitable for the work required;
- follow the scheduled maintenance and check periods shown in the manual;
- discover the reason for possible failures such as too much noise, overheating, oil blow-by, etc.

Refer to documents supplied by the dealer to carry out maintenance:

- Functional drawing of the electric and hydraulic equipment
- Exploded views with all data necessary for spare parts ordering
- List of possible faults and relevant solutions.

10.1 ORDINARY MAINTENANCE

The lift has to be properly cleaned at least once a month. Use self-cleaning clothes.



The use of water or inflammable liquid is strictly forbidden

Be sure the rod of the hydraulic cylinders is always clean and not damaged since this may result in leakage from seals and, as a consequence, in possible malfunctions.

10.2 PERIODIC MAINTENANCE

Every 3 months	Hydraulic circuit	<ul style="list-style-type: none"> ● Check oil level in the pump reservoir; refill with oil, if needed; ● check the circuit for oil leakage. ● Check seals for proper conditions and replace them, if necessary;
	Safety	<ul style="list-style-type: none"> ● check safety devices for proper operation
Every 6 months	Oil	<ul style="list-style-type: none"> ● Check oil for contamination or ageing. Contaminated oil is the main reason for failure of valves and shorter life of the pump
Every 12 months	General check	<ul style="list-style-type: none"> ● verify that all components and mechanisms are not damaged

CHAPTER 11 - TROUBLESHOOTING

A list of possible troubles and solutions is given below:

TROUBLE:	POSSIBLE CAUSE:	SOLUTION:
The lift does not work	There is no supply	Check and restore if necessary
The lift does not raise	The air circuit is disconnected	Replace
	The oil in the pump reservoir is not sufficient.	Add hydraulic oil
	The pump is faulty	Check and replace if necessary.
	The lowering valve stays opened	Check and clean if dirty, or replace if faulty.
	The suction pump filter is dirty.	Check and clean if needed
The lifting capacity is not sufficient	The hydraulic pump is faulty	Check the pump and replace, if needed
The lift does not lower	The pump is faulty	Check and replace if necessary.
when the lowering pedal is pressed	The mechanical safety is not released.	Check and release it.
The platform does not stop in standing position	The lowering valve does not work properly	Check and clean if dirty, or replace if faulty
	The lowering valve stays opened	Check and clean if dirty, or replace if faulty
	Oil leakage in the hydraulic pipeline	Check connections for proper tightening and the hose for damages (replace if damaged).
The lift does not lower smoothly	Air in the hydraulic system	Bleed the hydraulic system